

Drywall Stud Submittal

Code Approvals and Performance Standards

AISI “North American Specification for the Design of Cold-Formed Steel Structural Members”

ASTM American Society for Testing and Materials

- A653** Standard Specification for Steel Sheet, Zinc - Coated (Galvanized) or Zinc - Iron Alloy - Coated by the Hot - Dip Process
- A1003** Standard Specification for Steel Sheet, Carbon, Metallic - and Nonmetallic-Coated for Cold-Formed Framing Members
- C645** Standard Specification for Non-structural Steel Framing Members
- C754** Standard Specification for Installation of Steel Framing Members to Receive Screw - Attached Gypsum Panel Products
- C955** Standard Specification for Load-Bearing (Transverse and Axial) Steel Studs, Runners (Tracks), and Bracing or Bridging for Screw Application of Gypsum Panel Products and Metal Plaster Bases
- E119** Standard Test Methods for Fire Tests of Building Construction and Materials
- E72** Standard Test Methods of Conducting Strength Tests of Panels for Building Construction
- E90** Standard Test Method for Laboratory Measurement of Airborne Sound Transmission Loss of Building Partitions and Elements

UL Underwriters Laboratories Supreme Framing Classification

UL 263 Fire Tests of Building Construction and Materials

Steel Framing Members Fire Resistance Classification

U411 U412 U419 U435 U465 U493 V486 V496 V498

ICC-ES Code Approvals

ICC-ES ESR2507 30EQD & 33EQD

ICC-ES ESR3054 43EQS

Independent Product Certification

- Code Compliance - ICC Evaluation Services, LLC
- Fire Testing - Underwriters Laboratories, Inc.
- Sound Ratings - Riverbank Acoustical Laboratories
- 3rd Party Testing - Architectural Testing, Inc.
- Structural Testing - O.S.U. (Oregon State University)
- Structural Engineer - Devco Engineering



Supreme is Certified!

All inspections and testing for the Supreme Steel Framing System Association is provided by Architectural Testing, Inc. SSFSA sponsors a third-party certification program requiring that products are continually audited in order to ensure consistent quality and compliance to ASTM C645, C955 and 2006 IBC Codes.



Look for the sticker! 3rd Party Certified Code Compliant by nationally recognized Architectural Testing, Inc.

Products must be tested twice a year on unannounced visits. Steel is chemically stripped and tested for coating weight and bare metal thickness; and the dimensional properties of the stud are measured. All requirements must be satisfied in order to earn certification. All members of the SSFSA must satisfy the ASTM requirements each time they are audited.

All certified Supreme Steel has a label showing that it is third-party certified. Labels may be located on bundles or each framing member. The third-party certification label guarantees to the contractor and owner that materials are high quality and code compliant.

30EQD & 33EQD Stud Profile

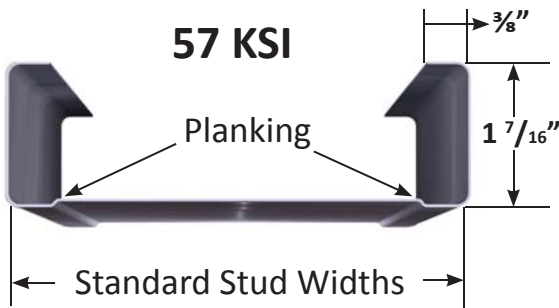

Available Sizes

1 5/8", 2 1/2", 3 1/2", 3 3/8", 4", 5 1/2" & 6"

33EQS & 43EQS Stud Profile

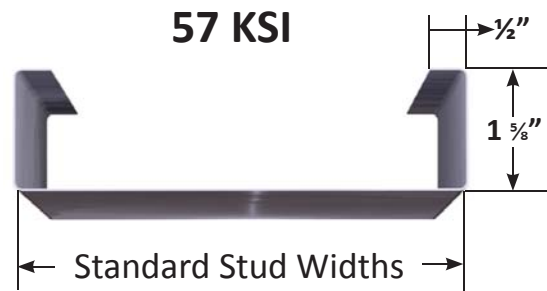

Available Sizes

2 1/2", 3 1/2", 3 3/8", 4", 5 1/2", 6" & 8"

Screw Capacity - Per AISI Section E4

Steel Thickness		Steel Prop.		Allowable Loads (lb/screw)											
Mils	Design (in)	Fy (ksi)	Fu (ksi)	No. 12 - 0.216 in. dia.			No. 10 - 0.190 in. dia.			No. 8 - 0.164 in. dia.			No. 6 - 0.138 in. dia.		
				Shear	Pullout	Pullover	Shear	Pullout	Pullover	Shear	Pullout	Pullover	Shear	Pullout	Pullover
30EQD	0.0235	57	65	152	93	191	143	82	191	133	71	191	122	60	191
33EQD	0.0235	57	65	152	93	191	143	82	191	133	71	191	122	60	191
33EQS	0.0295	57	65	214	117	240	201	103	240	187	89	240	171	75	240
43EQS	0.0400	57	65	338	159	325	317	140	325	295	121	325	270	102	325

Table Notes:

1. All values assume that the nominal strength of the screw itself is at least 1.25 times the design strength. Listed values use a factor of safety of 3.
2. Pullover values assume a minimum head/washer diameter, d_w , of 1/4"

Weld Capacity - 2001 NASPEC with 2004 Supplement

Steel Thickness		Fy (ksi)	Fu (ksi)	Nominal Weld Size	Weld Type			
Mils	Design				Fillet		Flare Groove	
					Longitudinal ¹	Transverse	Longitudinal ²	Transverse
43EQS	0.0400	57	65	1/16	639	1106	696	849

Table Notes:

1. For welds with $L/t > 25$ where L is weld length and t is the thickness of the welded member.
2. For $t \leq tw < 2t$ where t = thickness of welded member and tw is effective throat thickness of weld.
3. Weld capacities based on 2001 NASPEC (including 2004 Supplement), Sections E2.4 and E2.5
4. When connecting materials of different steel thickness or tensile strength (F_u), the lowest applicable values should be used.

Supreme Drywall Stud Section Properties

Stud Member	Design Thickness	Gross Properties							Effective Properties				Torsional Properties					
		Area (in. ²)	Weight (lbs/ft.)	Ixx (in. ⁴)	Sxx (in. ³)	Rx (in.)	Iyy (in. ⁴)	Ry (in.)	Ixx (in. ⁴)	Sxx (in. ³)	Ma (ft-lbs)	Va (lbs)	Jx1000 (in. ⁴)	Cw (in. ⁶)	m (in.)	Xo (in.)	Ro (in.)	β
162SFS-30EQD	0.0235	0.117	0.40	0.055	0.068	0.684	0.035	0.543	0.052	0.048	136	621	0.022	0.027	0.776	-1.359	1.616	0.292
250SFS-30EQD	0.0235	0.138	0.47	0.145	0.116	1.025	0.041	0.542	0.136	0.090	255	505	0.025	0.060	0.716	-1.212	1.677	0.478
350SFS-30EQD	0.0235	0.161	0.55	0.313	0.179	1.392	0.046	0.531	0.304	0.112	319	351	0.030	0.119	0.659	-1.083	1.842	0.655
362SFS-30EQD	0.0235	0.164	0.56	0.339	0.187	1.437	0.046	0.529	0.331	0.116	331	338	0.030	0.128	0.652	-1.069	1.867	0.672
400SFS-30EQD	0.0235	0.173	0.59	0.427	0.213	1.569	0.047	0.524	0.417	0.129	367	305	0.032	0.159	0.634	-1.029	1.949	0.721
600SFS-30EQD*	0.0235	0.220	0.75	1.112	0.371	2.247	0.053	0.492	0.976	0.219	622	200	0.041	0.388	0.553	-0.864	2.457	0.876

Table Notes

1. Gross Properties based on full-unreduced cross section of the studs, away from punchouts
2. For deflection calculations, use effective moment of inertia
3. *Web-height to thickness ratio exceeds 200, web stiffeners required at all support points

Supreme Drywall Track Section Properties

Track Member	Gross Properties							Torsional Properties						
	Area (in. ²)	Weight (lbs/ft.)	Ixx (in. ⁴)	Sxx (in. ³)	Rx (in.)	Iyy (in. ⁴)	Ry (in.)	Jx1000 (in. ⁴)	Cw (in. ⁶)	m (in.)	Xo (in.)	Ro (in.)	β	
162SFT125-30EQD	0.097	0.33	0.052	0.060	0.734	0.016	0.410	0.018	0.009	0.502	-0.874	1.213	0.481	
162SFT150-30EQD	0.109	0.37	0.061	0.070	0.749	0.027	0.496	0.020	0.014	0.623	-1.102	1.422	0.399	
162SFT200-30EQD	0.132	0.45	0.079	0.090	0.771	0.058	0.661	0.024	0.032	0.868	-1.571	1.871	0.295	
250SFT125-30EQD	0.118	0.40	0.130	0.099	1.052	0.019	0.399	0.022	0.023	0.458	-0.765	1.361	0.684	
250SFT150-30EQD	0.129	0.44	0.150	0.114	1.077	0.031	0.487	0.024	0.037	0.576	-0.979	1.535	0.593	
250SFT200-30EQD	0.153	0.52	0.190	0.144	1.115	0.067	0.660	0.028	0.080	0.816	-1.424	1.926	0.453	
250SFT250-30EQD	0.176	0.60	0.230	0.175	1.142	0.121	0.829	0.033	0.148	1.059	-1.885	2.355	0.359	
350SFT125-30EQD	0.141	0.48	0.275	0.151	1.396	0.021	0.381	0.026	0.048	0.417	-0.673	1.595	0.822	
350SFT150-30EQD	0.153	0.52	0.313	0.172	1.431	0.034	0.471	0.028	0.078	0.530	-0.871	1.740	0.749	
350SFT200-30EQD	0.176	0.60	0.389	0.215	1.486	0.074	0.649	0.033	0.170	0.763	-1.291	2.072	0.612	
350SFT250-30EQD	0.200	0.68	0.466	0.257	1.527	0.135	0.823	0.037	0.311	1.002	-1.731	2.450	0.501	
362SFT125-30EQD	0.144	0.49	0.297	0.158	1.437	0.021	0.379	0.027	0.052	0.412	-0.663	1.628	0.834	
362SFT150-30EQD	0.156	0.53	0.338	0.180	1.474	0.034	0.469	0.029	0.085	0.525	-0.859	1.769	0.764	
362SFT200-30EQD	0.179	0.61	0.420	0.224	1.531	0.075	0.647	0.003	0.184	0.758	-1.276	2.095	0.629	
362SFT250-30EQD	0.203	0.69	0.502	0.267	1.573	0.137	0.822	0.037	0.336	0.995	-1.713	2.467	0.518	
400SFT125-30EQD	0.153	0.52	0.373	0.181	1.562	0.021	0.373	0.028	0.065	0.399	-0.635	1.727	0.865	
400SFT150-30EQD	0.165	0.56	0.422	0.205	1.602	0.035	0.462	0.030	0.106	0.510	-0.826	1.861	0.803	
400SFT200-30EQD	0.188	0.64	0.521	0.252	1.665	0.077	0.641	0.035	0.229	0.740	-1.234	2.169	0.676	
400SFT250-30EQD	0.212	0.72	0.620	0.300	1.712	0.141	0.817	0.039	0.419	0.976	-1.664	2.523	0.565	
600SFT125-30EQD	0.200	0.68	0.970	0.317	2.204	0.023	0.341	0.037	0.163	0.340	-0.520	2.290	0.948	
600SFT150-30EQD	0.212	0.72	1.080	0.352	2.259	0.039	0.428	0.039	0.267	0.442	-0.688	2.400	0.918	
600SFT200-30EQD	0.235	0.80	1.299	0.424	2.351	0.086	0.606	0.043	0.578	0.658	-1.053	2.646	0.842	
600SFT250-30EQD	0.259	0.88	1.518	0.495	2.423	0.159	0.785	0.048	1.052	0.883	-1.446	2.929	0.756	

Table Notes

1. Effective section properties shown only for sections complying with NASPEC Section B1.

30EQD & 33EQD Drywall Studs & Track Composite Limiting Wall Heights



Interior COMPOSITE Wall Heights - 5/8" GWB Full Height													
Stud Member	Spacing (in.) o.c.	5 psf			7.5 psf			10 psf			15 psf		
		L/120	L/240	L/360	L/120	L/240	L/360	L/120	L/240	L/360	L/120	L/240	L/360
162SFS-30EQD	16	12' 10"	10' 2"	8' 9"	11' 2"	8' 9"	-	10' 2"	-	-	-	-	-
162SFS-30EQD	24	11' 6"	9' 1"	-	10' 0"	-	-	9' 1"	-	-	-	-	-
250SFS-30EQD	16	15' 7"	12' 5"	10' 10"	13' 8"	10' 10"	9' 5"	12' 5"	9' 9"	8' 6"	9' 3"f	8' 6"	-
250SFS-30EQD	24	13' 7"	10' 10"	9' 5"	11' 11"	9' 5"	8' 3"	10' 10"	8' 7"	-	-	-	-
362SFS-30EQD	16	20' 5"	15' 8"	13' 8"	17' 10"	13' 8"	12' 0"	16' 3"	12' 5"	10' 10"	11' 1"f	10' 10"	9' 4"
362SFS-30EQD	24	18' 7"	14' 3"	12' 5"	15' 8"f	12' 5"	10' 9"	13' 3"f	11' 3"	9' 8"	9' 1"f	9' 1"f	8' 4"
400SFS-30EQD	16	20' 9"	16' 6"	14' 5"	18' 2"	14' 5"	12' 7"	16' 6"	13' 1"	11' 5"	11' 5"f	11' 5"f	9' 9"
400SFS-30EQD	24	18' 9"	14' 8"	12' 10"	16' 0"f	12' 10"	11' 2"	13' 7"f	11' 8"	10' 1"	9' 4"f	9' 4"f	8' 9"
600SFS-30EQD	16	28' 6"	21' 6"	18' 9"	24' 11"	18' 9"	16' 5"	21' 11"f	17' 1"	14' 11"	13' 4"f	13' 4"f	13' 0"
600SFS-30EQD	24	24' 9"	18' 6"	16' 6"	20' 6"f	16' 2"	14' 5"	16' 6"f	14' 8"f	13' 1"	10' 4"f	10' 4"f	10' 4"f

Table Notes

1. f: Flexural stress controls allowable height
2. 5/8" Gypsum Board both sides full height
3. Tested per 2008 ICC ES Acceptance Criteria AC-86
4. Galvanizing to be G-40 Minimum for 10 PSF or less & G-60 Minimum for Greater than 10 PSF Lateral Loads

Allowable Wall Heights for Superimposed Axial Load and 5psf Lateral Load Placed on Each Stud						
Stud Member	1/2" Minimum Gypsum Board On Each Stud Flange				Composite Heights with Revised β_0 Zero Axial Load	
	100 lb. Load		50 lb. Load		16" o.c.	24" o.c.
	16" o.c.	24" o.c.	16" o.c.	24" o.c.		
162SFS-30EQD	10' 0"	8' 8"	10' 0"	8' 8"	12' 10"	11' 6"
250SFS-30EQD	13' 11"	11' 10"	13' 11"	11' 10"	15' 7"	13' 7"
362SFS-30EQD	17' 8"	14' 11"	18' 8"	15' 7"	20' 5"	18' 7"
400SFS-30EQD	18' 9"	15' 10"	19' 9"	16' 4"	20' 9"	18' 9"
600SFS-30EQD	23' 9"	19' 9"	24' 8"	20' 4"	28' 6"	24' 9"

Table Notes:

1. L/120 Deflection Limits
2. Sheathing installed full height of the wall - each side
3. Allowable heights based on Cold-Formed Steel Framing - Wall Stud Design, 2007 Edition
4. Gypsum sheathing installed with No. 6 fasteners at 12" o.c. max.



30EQD & 33EQD Drywall Studs & Track Non-Composite Limiting Wall Heights

Interior NON-COMPOSITE Chase Wall or Non-Clad Wall Height													
Stud Member	Spacing (in.) o.c.	5 psf			7.5 psf			10 psf			15 psf		
		L/120	L/240	L/360	L/120	L/240	L/360	L/120	L/240	L/360	L/120	L/240	L/360
162SFS-30EQD	16	10' 0"	-	-	8' 9"	-	-	-	-	-	-	-	-
162SFS-30EQD	24	8' 9"	-	-	-	-	-	-	-	-	-	-	-
250SFS-30EQD	16	13' 10"	11' 0"	9' 7"	12' 1"	9' 7"	8' 4"	11' 0"	8' 8"	-	9' 2"	-	-
250SFS-30EQD	24	12' 1"	9' 7"	8' 4"	10' 7"	8' 4"	-	9' 2"	-	-	-	-	-
350SFS-30EQD	16	18' 0"	14' 4"	12' 7"	14' 8"	12' 7"	10' 11"	12' 8"	11' 5"	9' 11"	10' 4"	9' 11"	8' 8"
350SFS-30EQD	24	14' 8"	12' 7"	10' 11"	11' 11"	10' 11"	9' 7"	10' 4"	9' 11"	8' 8"	8' 6"	8' 6"	-
362SFS-30EQD	16	18' 4"	14' 9"	12' 11"	14' 11"	12' 11"	11' 3"	12' 11"	11' 9"	10' 3"	10' 6"	10' 3"	8' 11"
362SFS-30EQD	24	14' 11"	12' 11"	11' 3"	12' 2"	11' 3"	9' 10"	10' 6"	10' 3"	8' 11"	8' 8"	8' 8"	-
400SFS-30EQD	16	19' 3"	16' 0"	13' 11"	15' 8"	13' 11"	12' 2"	13' 7"	12' 8"	11' 1"	11' 1"	11' 1"	9' 8"
400SFS-30EQD	24	15' 8"	13' 11"	12' 2"	12' 10"	12' 2"	10' 8"	11' 1"	11' 1"	9' 8"	8' 8"	8' 8"	8' 5"

Table Notes

1. End lateral bearing - 1 inch minimum
2. Heights based on steel properties only
3. Limiting heights based on 1/2" minimum gypsum wall board attached to each face to within 4 feet of the end of the stud OR 1/2" minimum gypsum wall board attached to one face and the unsheathed flange laterally braced at 4 foot o.c. for the length of the stud
4. Galvanizing to be G-40 Minimum for 10 PSF or less & G-60 Minimum for Greater than 10 PSF Lateral Loads

Example of lateral bracing at wall not sheathed full-height.

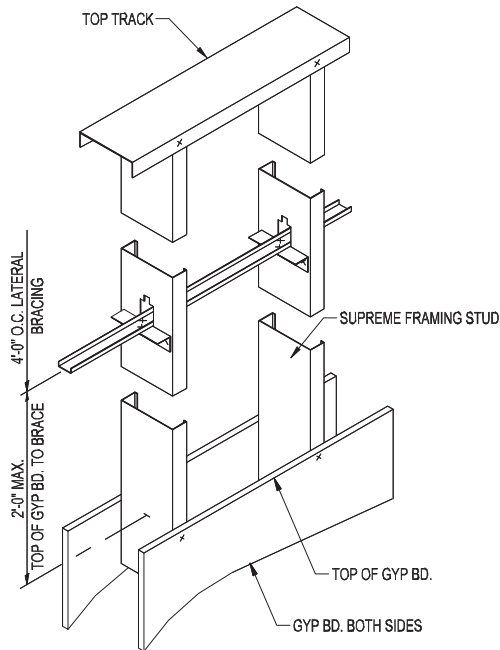

Example of lateral bracing at wall sheathed full-height on one side.

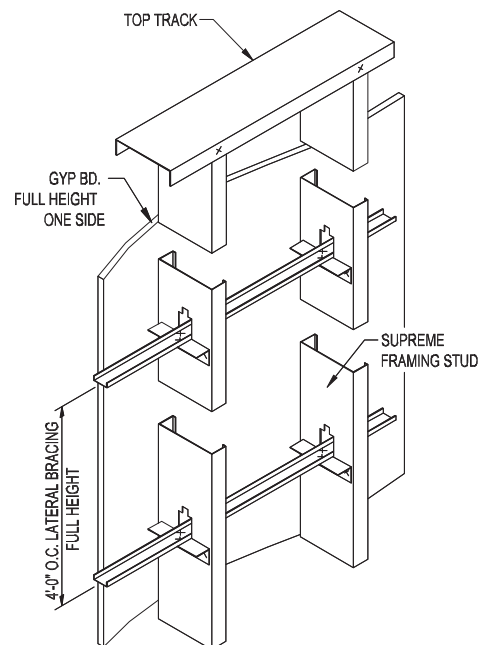

30EQD & 33EQD Drywall Studs & Track

Allowable Ceiling Spans

Allowable Ceiling Spans - DEFLECTION LIMIT L/240

Stud Member	4 psf				6 psf				13 psf			
	Lateral Support of Top Flange		Midspan		Lateral Support of Top Flange		Midspan		Lateral Support of Top Flange		Midspan	
	Unsupported Joist spacing o.c.		Joist spacing o.c.		Unsupported Joist spacing o.c.		Joist spacing o.c.		Unsupported Joist spacing o.c.		Joist spacing o.c.	
	16"	24"	16"	24"	16"	24"	16"	24"	16"	24"	16"	24"
162SFS-30EQD	8' 7"	7' 6"	8' 7"	7' 6"	7' 6"	6' 6"	7' 6"	6' 6"	5' 9"	5' 0"	5' 9"	5' 0"
250SFS-30EQD	9' 10"	8' 10"	11' 10"	10' 4"	8' 10"	7' 11"	10' 4"	9' 0"	7' 2"	6' 4"	8' 0"	6' 11"
362SFS-30EQD	10' 8"	9' 7"	15' 4"	13' 7"	9' 7"	8' 8"	13' 7"	12' 0"	7' 10"	7' 0"	10' 8"	9' 2"
400SFS-30EQD	11' 0"	9' 10"	15' 9"	14' 0"	9' 10"	8' 10"	14' 0"	12' 4"	8' 1"	7' 2"	11' 0"	9' 7"

Allowable Ceiling Spans - DEFLECTION LIMIT L/360

Stud Member	4 psf				6 psf				13 psf			
	Lateral Support of Top Flange		Midspan		Lateral Support of Top Flange		Midspan		Lateral Support of Top Flange		Midspan	
	Unsupported Joist spacing o.c.		Joist spacing o.c.		Unsupported Joist spacing o.c.		Joist spacing o.c.		Unsupported Joist spacing o.c.		Joist spacing o.c.	
	16"	24"	16"	24"	16"	24"	16"	24"	16"	24"	16"	24"
162SFS-30EQD	7' 6"	6' 6"	7' 6"	6' 6"	6' 6"	5' 8"	6' 6"	5' 8"	5' 0"	4' 5"	5' 0"	4' 5"
250SFS-30EQD	9' 10"	8' 10"	10' 4"	9' 0"	8' 10"	7' 10"	9' 0"	7' 10"	6' 11"	6' 1"	6' 11"	6' 1"
362SFS-30EQD	10' 8"	9' 7"	13' 11"	12' 2"	9' 7"	8' 8"	12' 2"	10' 7"	7' 10"	7' 0"	9' 4"	8' 2"
400SFS-30EQD	11' 0"	9' 10"	15' 0"	13' 1"	9' 10"	8' 10"	13' 1"	11' 5"	8' 1"	7' 2"	10' 2"	8' 10"

Table Notes

1. Values are for single spans
2. For fully braced ceilings, use mid-span values
3. End bearing length is 1 inch minimum
4. Galvanizing to be G-40 Minimum for 10 PSF or less & G-60 Minimum for Greater than 10 PSF Lateral Loads

